

xCDT Family Sensor | Application Note

SPECIMEN



TABLE OF CONTENTS

1. HISTORY OF MODIFICATION	3
2. GLOSSARY	4
3. INTRODUCTION.....	5
4. SENSOR LOCATION IN THE APPLICATION	6
5. SENSOR ARCHITECTURES.....	7
5.1. DCDT SENSORS.....	7
5.2. CDT SENSORS	8
6. TESTING THE SENSOR	9
6.1. GENERIC TEST SET-UP	9
6.2. VERIFICATION OF MEASUREMENT CHANNELS (AC AND/OR DC)	11
6.3. VERIFICATION OF LOW FREQUENCY SENSING ELEMENT TEST/INJECTION WINDING	12
6.4. VERIFICATION OF HIGH FREQUENCY SENSING ELEMENT TEST/INJECTION WINDING (DCDT ONLY)	13
6.5. HIGH FREQUENCY SENSING ELEMENT INTERFACE CIRCUIT OF MEASUREMENT OUTPUT (DCDT ONLY)	14
6.5.1. <i>Measurement using resistor</i>	14
6.5.2. <i>Measurement using transimpedance amplifier circuit</i>	15
6.6. TEST WINDING INTERFACE CIRCUIT FOR LOW FREQUENCY SENSING ELEMENT.....	16
6.6.1. <i>Disconnect injection circuit when not used</i>	16
6.6.2. <i>Test Circuit 1: AC and/or DC test capability</i>	16
6.6.3. <i>Test Circuit 2: DC or DC+AC test capability</i>	19
7. SW INTEGRATION	22



1. History of Modification

Date	Type of Modification	Who	Pages	Version
05/08/2020	Creation	DCO		V0
07/12/2020	Update schematics related to latest version Add CDT Sensor paragraphs Update graphs with SPI symbols	DCO	all all all	V1
26/03/2021	Correct test current values Add Paragraph 6.3 Test winding interface circuit	DCO	12/18 19-24	V2
14/06/2020	Correct test current values	DCO	12/18	V3
24/08/2022	Correct SPI bus recommended schematic. Removed redundant CDT section. Add VCC supply filtering capacitor. Added SW integration section	DBa	9-13 9-13 9-13 22	V5

SPECIMEN



2. Glossary

AC: Alternating Current

CT: Current Transformer

DAC: Digital to Analog Converter

DC: Direct Current

EMC: Electro Magnetic Compatibility

GBW : Gain Band Width (used for operational amplifier)

MCU: Micro-Controller Unit

MOSFET: Metal Oxide Semiconductor Field Effect Transistor

OBC: On-Board Charger

PWM: Pulse Width Modulation

TBD: To Be Defined

SPECIMEN



3. Introduction

xCDT sensor family are leakage current sensors dedicated to measure AC and DC leakage current in any single to 3 phase applications and up to 22kW of charging power.

This family is specially design for automotive On-Board Charger embedded in plug-in hybrid or electric vehicle.

This application note aims to describe the environment in which the xCDT family sensors are used in customer or test environment.

It covers the following references of DCDT sensors:

Reference	Number of Primary Conductors	Item Number	Primary Conductor 1 Pin 13/17	Primary Conductor 2 Pin 14/18	Primary Conductor 3 Pin 15/19	Primary Conductor 4 Pin 16/20
DCDT 0.3-S2	2	90.W4.A2.2xx.0	Mounted		Mounted	
DCDT-SF 0.3-S2	2	90.W6.A2.2xx.0	Mounted		Mounted	
DCDT 0.3-S4	4	90.W4.A2.4xx.0	Mounted	Mounted	Mounted	Mounted
DCDT-SF 0.3-S4	4	90.W6.A2.4xx.0	Mounted	Mounted	Mounted	Mounted

It covers the following references of CDT sensors:

Reference	Number of Primary Conductors	Item Number	Primary Conductor 1 Pin 13/17	Primary Conductor 2 Pin 14/18	Primary Conductor 3 Pin 15/19	Primary Conductor 4 Pin 16/20
CDT 0.3-S2	2	90.W3.A2.2xx.0	Mounted		Mounted	
CDT-SF 0.3-S2	2	90.W5.A2.2xx.0	Mounted		Mounted	
CDT 0.3-S4	4	90.W3.A2.4xx.0	Mounted	Mounted	Mounted	Mounted
CDT-SF 0.3-S4	4	90.W5.A2.4xx.0	Mounted	Mounted	Mounted	Mounted

The datasheet of each reference of sensor shall be used in addition to this application note.



4. Sensor location in the application

The differential sensor placement inside client application, typically a car on-board charger, must be chosen to minimize EMC interference. It shall be located after surge absorbers at position 4 to 5.

Typical value of common choke in the customer circuit would be 1mH but any value higher would be suitable.

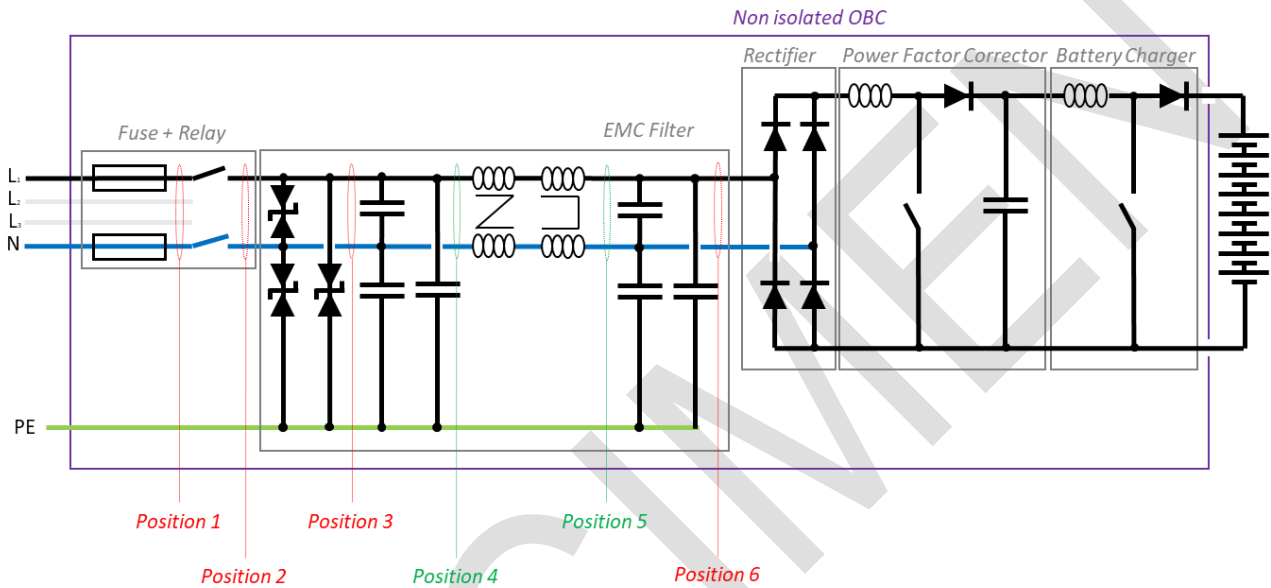

5. Sensor architectures

The sensor architectures are given as follow.

5.1. DCDT Sensors

Non-Safety Version (DCDT)

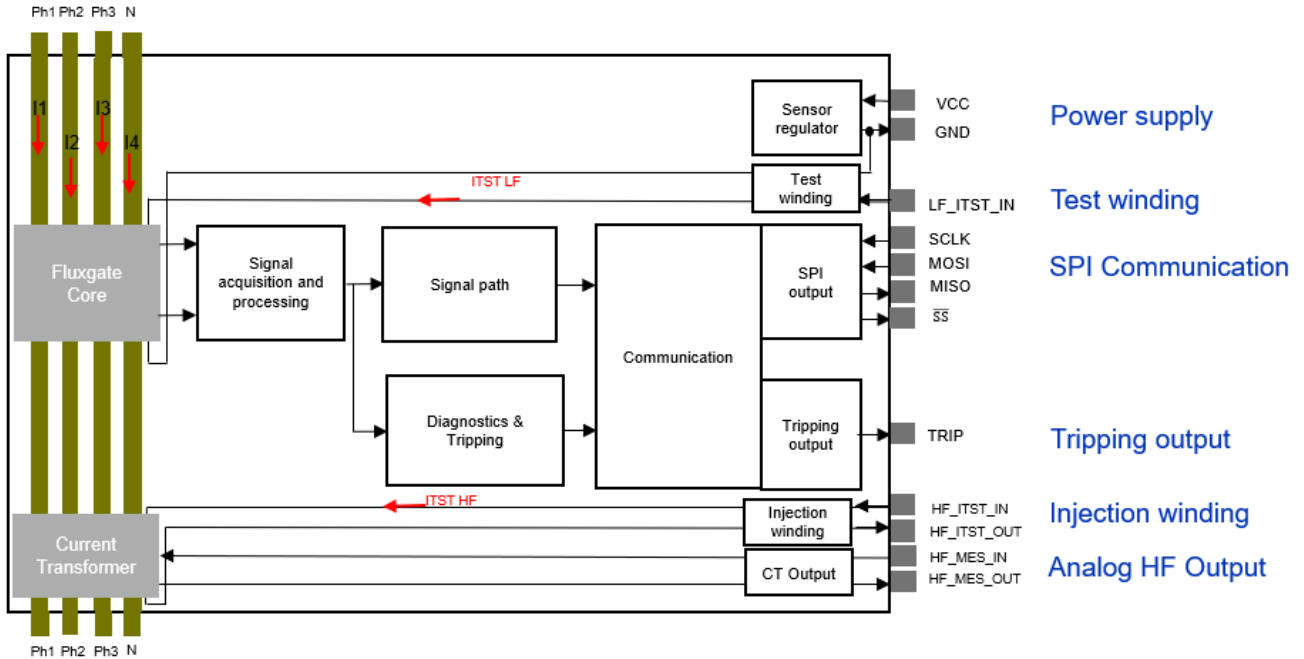

Safety Version (DCDT-SF)

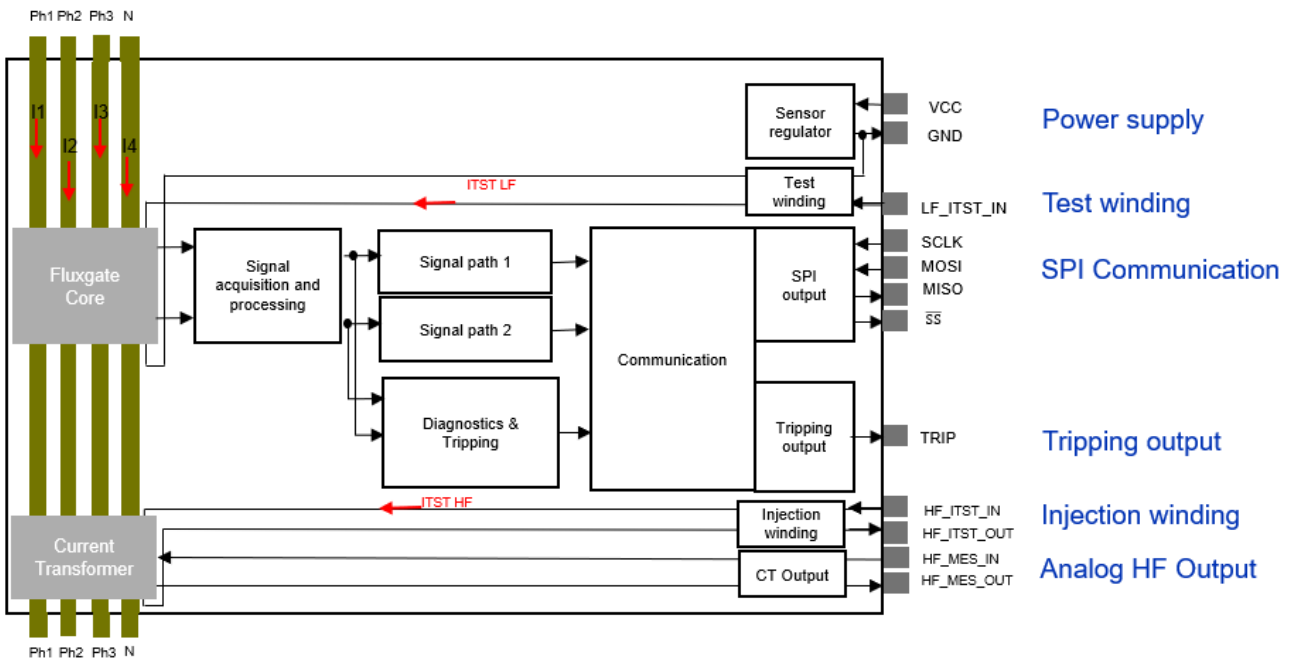

5.2. CDT Sensors

Non-Safety Version (CDT)

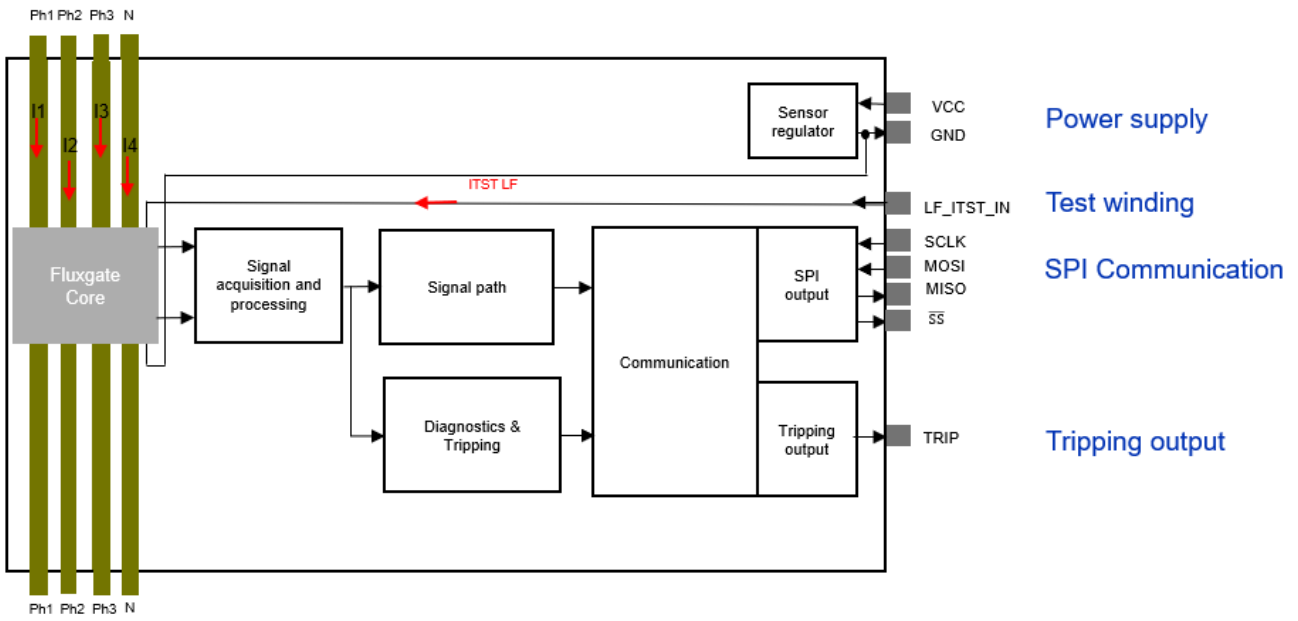

Safety Version (CDT-SF)

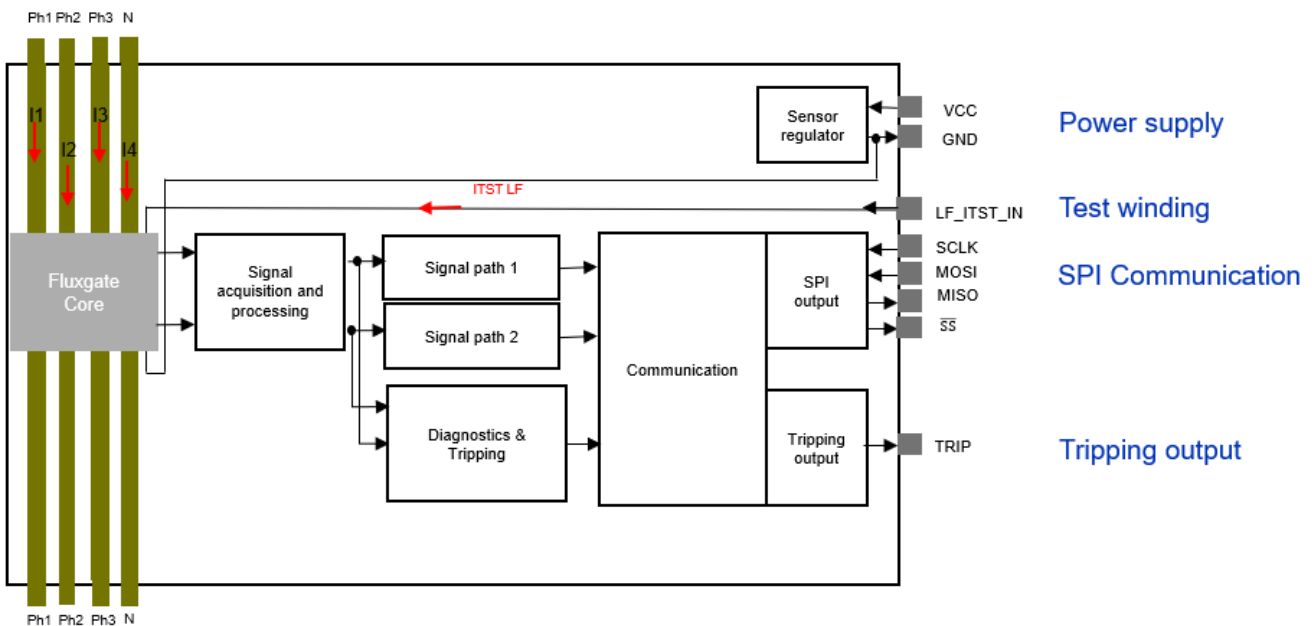

6. Testing the sensor

The following paragraph describe the test environment that can be used to validate the proper sensor operation. The test environment shall be representative to the application environment.

6.1. Generic Test Set-up

This generic test set-up can be used to validate the proper operation of the sensor:

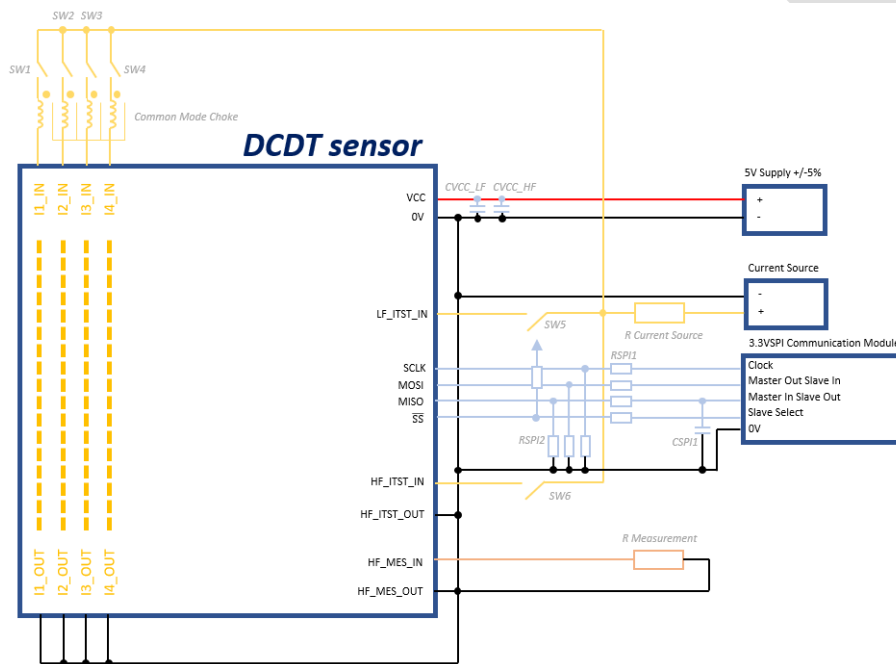

5V power supply shall be able to provide the supply voltage and current to the sensor.

The current source shall be able to source AC and DC current to be injected into the following sensor inputs:

- Jumpers
- Low Frequency Sensing Element Test/Injection Winding
- High Frequency Sensing Element Test/Injection Winding (DCDT only).

Switches SW1 to SW6 are used to connect the current source to one of the sensor inputs at a single time.

CVCC_LF and CVCC_HF are power supply filtering capacitor. CVCC_LF shall be 47 uF and CVCC_HF shall be 100 nF.

R Current source shall be very low value and can be used to measure the current injected by the current source. This resistance can be set to zero in the case a non-intrusive sensing element is used to measure the current from the current source (hall probe...).





Life Energy Motion

R Measurement is a resistance connected to the measurement winding of the high frequency sensing element channel. As this channel is a current transformer, the resistance used must be a very low value in order to ensure the proper operation of the CT especially in the low frequency range. The best solution would be to interface the CT with a transimpedance amplifier circuit (this will be detailed in a specific chapter).

RSPI1 are resistances used as an interface between the SPI module and the sensor to reduce circulating current due to 3V3 supply imbalance. Their value can be chosen in the range of 10Ω to 1kΩ considering the SPI clock frequency to be used (3x 100 pF capacitor set on CLK, MOSI, /SS to GND internally to sensor for EMC filtering).

RSPI2 are resistances used as pull-up/pull-down resistors. Their recommended value is 100kΩ.

CSPI1 is capacitor used to filter MISO signal that customer can choose to use if necessary. We recommend value 100 pF. Localization shall be close to customer SPI device.

3.3V SPI Communication Module is used to interface with the low frequency sensing element. It should operate in MASTER mode and shall be compatible with 3.3V signals.

SPECIMEN



6.2. Verification of measurement channels (AC and/or DC)

This test permits to validate the proper operation of all measurement channels. It consists of injecting current in the jumpers and measuring the outputs of the sensor. The test set-up shall be as follow:

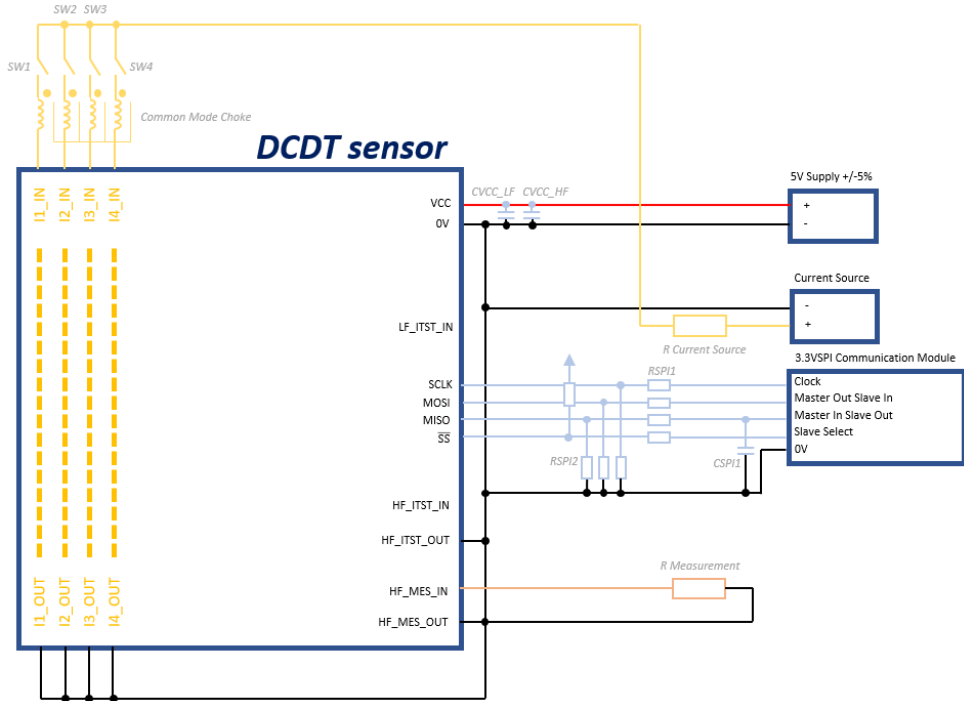

Any of the switches SW1, SW2, SW3 or SW4 shall be closed in order to inject current in the sensor jumpers.

The 3.3V SPI Communication Module will get the currents (channel 1 and 2) from the low frequency sensing element.

Current through R Measurement permit to validate the proper behavior of the High Frequency Sensing Element.

Both test windings shall be open during this test.

The following table summarizes values that can be tested and expected on the product:

	Current Source Value	I _x _IN Value	LF_ITST_IN Value	HF_ITST_IN Value	Low frequency element SPI	High Frequency Element HF_MES_IN
DC	100mADC	100mADC	0	0	100mADC	0
	200mADC	200mADC	0	0	200mADC	0
	300mADC	300mADC	0	0	300mADC	0
AC (50Hz)	100mARMS	100mARMS	0	0	100mARMS	1.25mARMS
	200mARMS	200mARMS	0	0	200mARMS	2.5mARMS
AC (20kHz)	100mARMS	100mARMS	0	0	Not applicable	1.25mARMS
	200mARMS	200mARMS	0	0	Not applicable	2.5mARMS



Note: For the high frequency sensing element, the ratio between primary and secondary depends on the number of turns that is given in the datasheet of the product.

6.3. Verification of Low Frequency Sensing Element Test/Injection Winding

This paragraph explains the way to verify the proper behavior of the Test/Injection winding of the low frequency sensing element.

The following test set-up shall be used:

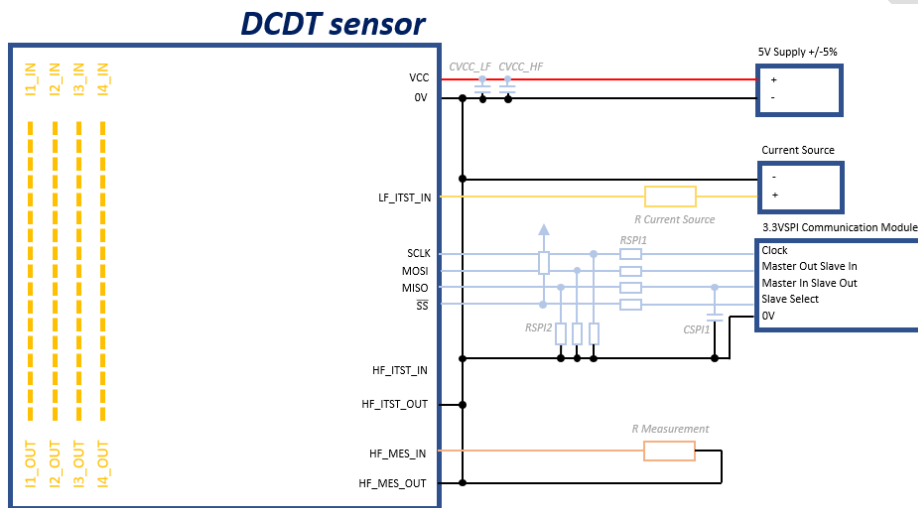

Primary jumpers are in open-circuit.

Current is injected through the Low Frequency Test/Injection winding using the current source.

3.3V SPI Communication module retrieves the measured current of the Low Frequency Sensing Element.

The following table summarizes values that can be tested and expected on the product:

	Current Source Value	I _x _IN Value	LF_ITST_IN Value	HF_ITST_IN Value	Low frequency element SPI	High Frequency Element HF_MES_IN
DC	6.25mADC	0	6.25mADC	0	100mADC	0
	12.5mADC	0	12.5mADC	0	200mADC	0
	18.75mADC	0	18.75mADC	0	300mADC	0
AC (50Hz)	6.25mARMS	0	6.25mARMS	0	100mARMS	0
	12.5mARMS	0	12.5mARMS	0	200mARMS	0

Note: For the low frequency test winding, the ratio between current injected and measured depends on the number of turns that is given in the datasheet of the product.



6.4. Verification of High Frequency Sensing Element Test/Injection Winding (DCDT only)

This paragraph explains the way to verify the proper behavior of the Test/Injection winding of the high frequency sensing element.

The following test set-up shall be used:

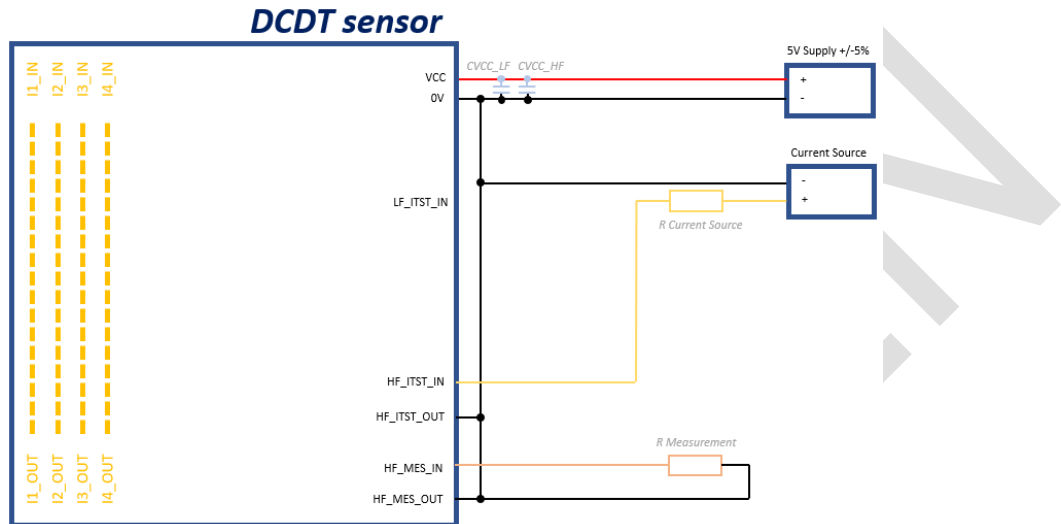

Primary jumpers are in open-circuit.

Current is injected through the High Frequency Test/Injection winding using the current source.

The following table summarizes values that can be tested and expected on the product:

	Current Source current	I _x _IN current	LF_ITST_IN current	HF_ITST_IN current	Low frequency element SPI	High Frequency Element HF_MES_IN
AC (50Hz)	1.25mARMS	0	0	1.25mARMS	0	1.25mARMS
	2.5mARMS	0	0	2.5mARMS	0	2.5mARMS
AC (20kHz)	1.25mARMS	0	0	1.25mARMS	0	1.25mARMS
	2.5mARMS	0	0	2.5mARMS	0	2.5mARMS

Note: For the high frequency test winding, the ratio between current injected and measured depends on the number of turns that is given in the datasheet of the product.



6.5. High Frequency sensing Element interface circuit of measurement output (DCDT only)

The High Frequency Sensing Element is a Current transformer. Characteristics of the CT is generally a bandpass filter when looking at frequency response. Low frequency is limited by the value of the magnetizing inductance. High frequency is limited by the parasitic elements and magnetic material characteristics. Secondary impedance play a large role in the bandwidth of the CT and that is the reason why the following chapter describe interface circuit for this part of the sensor.

6.5.1. Measurement using resistor

The use of a resistor is possible and convenient for customer as voltage across the resistor can directly be measured by an ADC.

The value of the resistor play a large role in the bandwidth of the sensor.

High value resistor will increase the voltage to be measured (easier for measurement) but drastically reduce the frequency bandwidth as for proper operation the measurement windings of a CT shall be in short circuit (or connected to a low impedance load).

Low value of resistor permits to properly bias the CT but direct voltage measurement is no more reachable and voltage amplification circuit is required.

The following graph highlight attenuation (Secondary current vs primary current) for different values of measurement resistors expressed in Ω :

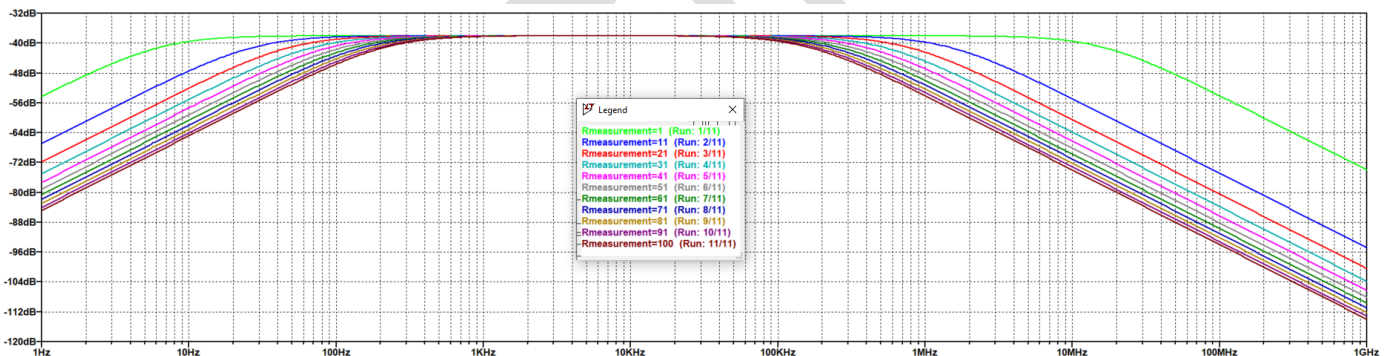

Note: The bandwidth presented is based on a model used to show the impact of the measurement resistance value. For actual bandwidth of the sensor, please refer to the datasheet and the set-up used for validation.



6.5.2. Measurement using transimpedance amplifier circuit

Transimpedance amplifier circuit uses standard operational amplifier circuit in which a current source I1 is connected at the input and feedback resistor RGAIN is used as amplification.

The circuit is given as follow:

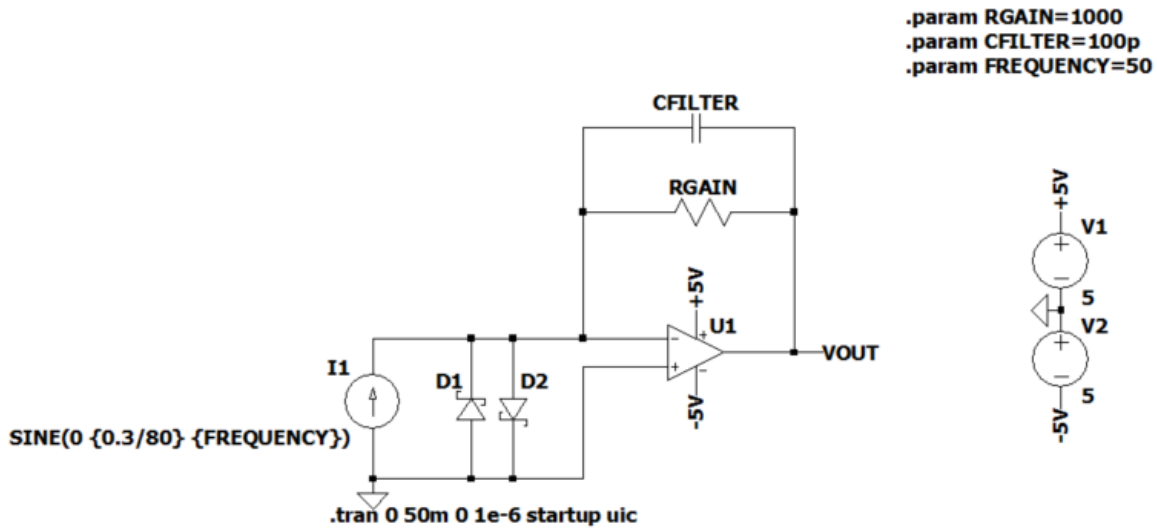

The output voltage is given as follow:

$$VOUT = -I1 \cdot RGAIN$$

The current source I1 corresponds to the sensor output (secondary of the current transformer). Diodes D1 and D2 are used for clamping the operational amplifier inputs during di/dt of the jumpers. These diodes shall be low leakage diodes to not impact the measurement in temperature.

Operational amplifier shall be selected with regards to the application requirement (bandwidth, accuracy...). In such circuit, the operational amplifier offset shall be minimized as it can lead to saturation of the CT magnetic core.

The capacitor CFILTER is used to filter the high frequencies depending on the requirement.

Voltage output of the circuit is given as follow:

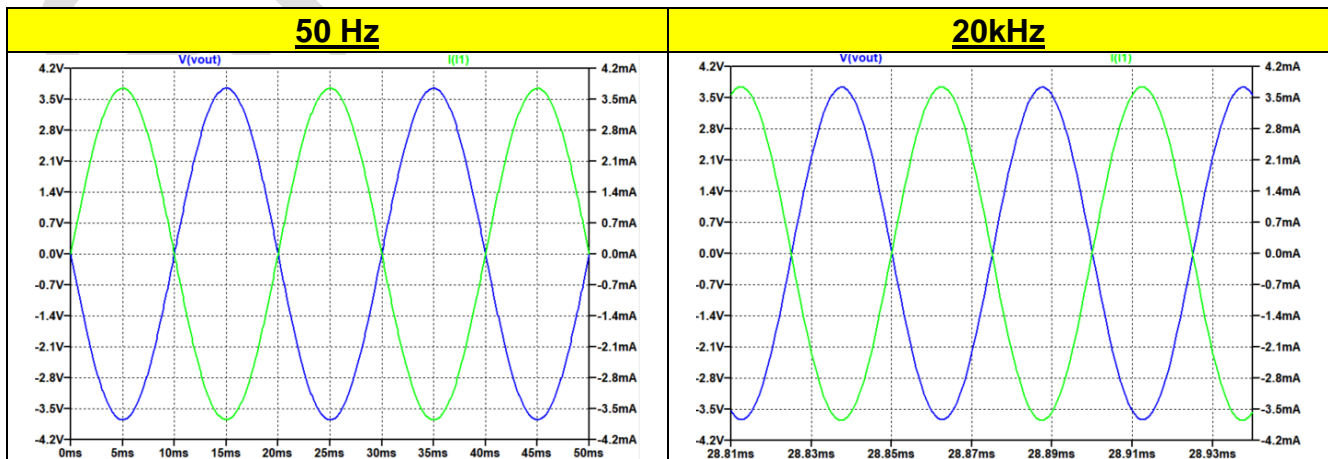

6.6. Test winding interface circuit for low frequency sensing element

As stated in both UL2231 and IEC62752 standards, it is mandatory to test the capability of the sensor to measure accurately leakage current and trip within a certain time prior any charging cycle.

This chapter highlights some circuits that can be used by customers to inject DC and/or AC current in the test winding and verify the proper behavior of the sensor for both measurement and tripping specifications.

In order to properly select the injection circuit, the customer shall define the following parameters for AC and/or DC characteristics to be tested by the Test/Injection winding:

Test n°	AC	Test n°	DC
Test 1: Primary Leakage Current value	TBD mARMS @ TBD Hz	Test 1: Primary Leakage Current value	TBD mADC
Test 2: Primary Leakage Current value	TBD mARMS @ TBD Hz	Test 2: Primary Leakage Current value	TBD mADC
...

This will help to define which test circuit must be used depending on the requirement.

6.6.1. Disconnect injection circuit when not used

When the test circuit is not supposed to be used to inject current, the customer shall disconnect it from the sensor Test/Injection winding instead of setting the test voltage to 0V. It removes any interference between the test circuit and the sensor that may degrade measurement performances of the sensor (operational amplifier offset...)

6.6.2. Test Circuit 1: AC and/or DC test capability

6.6.2.1. General Circuit

The following circuit is so called “Howland Current Pump”. It is the most generic circuit that operate as a current source. This circuit permits to test the overall sensor capabilities as DC range and AC range for positive and negative values of current with a limited number of electronic components:

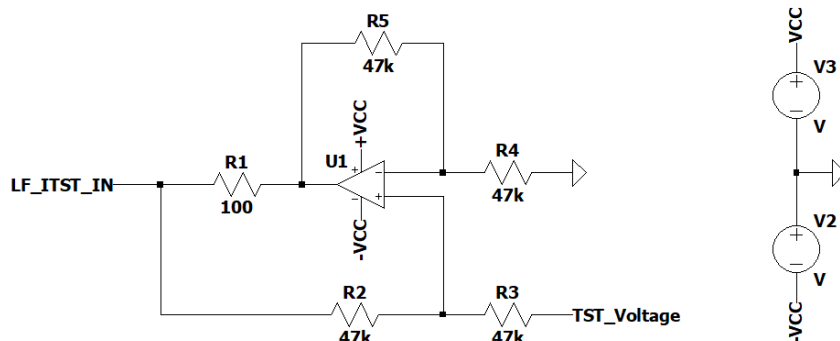

The TST_Voltage is a voltage provided by the customer and used to set-up the current injected through the test winding. When this voltage is positive, the current is sinked by the Test/Injection winding (leakage current measured is positive) and when it is negative, the current is sourced by the Test/Injection winding (leakage current measured is negative).



6.6.2.2. Supply Voltage

This circuit requires dual supply to operate correctly (positive and negative voltage). The supply voltage shall be high enough to be able to source/sink current to the Test/Injection winding.

As a guidance, the following table summarize the testable primary referred leakage current ranges versus the supply voltage of the circuit:

Supply Voltage	Testable primary referred leakage current range
+/-5V	+/-100mADC
+/-6V	+/-200mADC
+/-7V	+/-300mADC

The leakage current sensor shall be supplied within its nominal operating range to ensure proper operation during the injection test.

6.6.2.3. Leakage current as a function of Test Voltage

In the proposed circuit, $R2 = R3 = R4 = R5 = 47k\Omega$. The current through the Test/Injection winding can be calculated as follow:

$$I_{LF_ITST_IN} = \frac{V_{TST_voltage}}{R1} = 0.01 \cdot V_{TST_voltage}$$

With:

$I_{LF_ITST_IN}$: Current in the Test/Injection Winding expressed in Amperes.

$V_{TST_voltage}$: Test Voltage expressed in Volts.

$R1$: Resistor expressed in Ohms.

The resistor $R1$ shall be fixed to a value equal or higher than 100Ohms to ensure proper operation of the sensor. This resistor limits the maximum current sinked/sourced by the test circuit and the higher the resistor is, the lower the current range to be tested will be.

The leakage current measured by the sensor can be determined as follow:

$$I_{LEAKAGE} = I_{LF_ITST_IN} \cdot N_s = I_{LF_ITST_IN} \cdot 16$$

With:

$I_{LEAKAGE}$: Leakage current measured by the sensor expressed at primary side in Amperes.

$I_{LF_ITST_IN}$: Current in Test/Injection winding expressed in Amperes.

N_s : Number of turns of the Test/Injection winding given in the datasheet.



The following table summarize as an example several values of DC primary leakage current corresponding to test/injection winding voltage with supply voltage of +/-7V.

Primary Leakage Current	Test/Injection winding Leakage Current	Test Voltage
-300mADC	-18.75mADC	-1.875VDC
-100mADC	-6.25mADC	-0.625VDC
-6mADC	-0.375μADC	-0.0375VDC
6mADC	0.375μADC	0.0375VDC
100mADC	6.25mADC	0.625VDC
300mADC	18.75mADC	1.875VDC

To inject AC current, the test voltage shall be AC and the amplitude will define the amplitude of the current that will be injected in the Test/Injection winding.

6.6.2.4. Operational Amplifier characteristics

The Operational Amplifier characteristic have strong impact on the test circuit.

As a guideline, the following requirements shall be applied to this component in order to ensure proper operation of the circuit and the sensor:

Item	Value
Voltage supply	Dual and high enough to the current range to be tested
Inputs	Rail to rail
Output	Rail to rail
Output current sink/source	≥ +/-25mA
Output Slew Rate	≥ 10V/μs
GBW	≥ 20MHz
Input offset voltage	< 1mV



6.6.3. Test Circuit 2: DC or DC+AC test capability

6.6.3.1. General Circuit

When customer does not have a dual supply voltage available, the following circuit is a unipolar current source that permit to test only negative leakage current (sourced by the Test/Injection windings through the injection circuit):

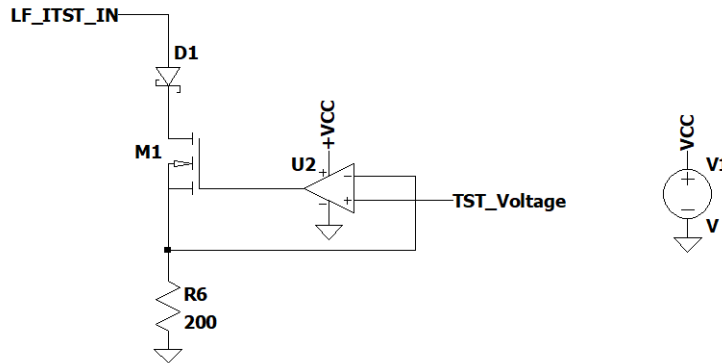

It permits to test DC and combined AC+DC values comprised in the measurement range of the sensor. It is not possible to test pure AC with such circuit due to the diode D1.

6.6.3.2. Supply Voltage

The supply voltage VCC of the injection circuit must be 5V or higher in order to properly drive the MOSFET M1.

The leakage current sensor shall be supplied within its nominal operating range to ensure proper operation during the injection test.

6.6.3.3. Leakage current as a function of Test Voltage and feedback measurement

The average current sourced by the Test/Injection winding can be approximated by the following equation:

$$I_{LF_ITST_IN} \approx -k \cdot \frac{V_{TST_Voltage}}{R6} \approx -\frac{1}{2} \cdot \frac{V_{TST_Voltage}}{200}$$

With:

$I_{LF_ITST_IN}$: Current in the Test/Injection Winding expressed in Amperes.

$V_{TST_Voltage}$: Setting voltage expressed in Volts.

k : Coefficient linked to the unipolarity of the circuit

$R6$: Resistor expressed in Ohms.



The resistor R6 shall be fixed to a value equal or higher than 200Ohms to ensure proper operation of the sensor. This resistor limits the maximum current sinked by the test circuit and the higher the resistor is, the lower the current range to be tested will be.

The coefficient k represents the diode that is forward biased only 50% of the time. The negative sign means that the current is going out of the LF_ITST_IN pin (sourced by the leakage current sensor).

The leakage current measured by the sensor can be estimated as follow:

$$I_{LEAKAGE} \approx I_{LF_ITST_IN} \cdot N_s \approx I_{LF_ITST_IN} \cdot 16$$

With:

$I_{LEAKAGE}$: Leakage current measured by the sensor expressed at primary side in Amperes.

$I_{LF_ITST_IN}$: Current in Test/Injection winding expressed in Amperes.

N_s : Number of turns of the Test/Injection winding given in the datasheet.

In the proposed circuit, the link between the leakage current measured and the Test Voltage is an approximation (that neglect some parameters). In order to verify accurately the operation of the sensor, the customer shall measure the resistor R6 voltage that corresponds to the real current sinked from the Test/Injection and shall compare this current with those one measured by the measurement channels of the sensor.

The following circuit can be used for Test/Injection winding current measurement:

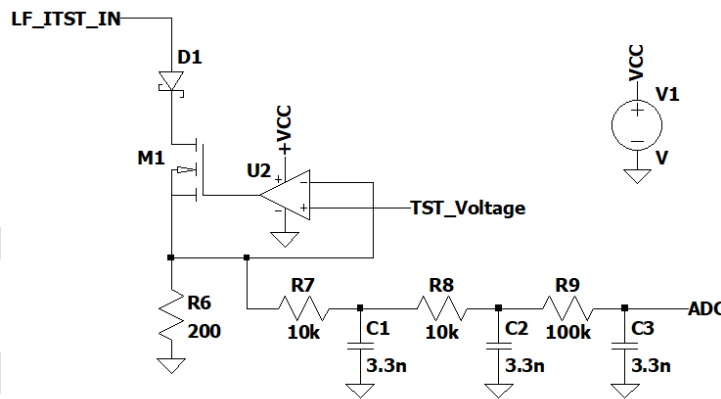

The 3rd order low pass filter removes the high frequency content of the current in order to measure only the average or low frequency content. It allows the customer to test the sensor measurement and tripping capability for DC and DC+AC leakage currents with AC content of 50Hz or 60Hz.

The following table summarize as an example several values of DC primary leakage current corresponding to test/injection winding voltage that can be used by the customer:

Average Primary Leakage Current	Average Test/Injection winding Leakage Current	Test Voltage
-10mADC	-0.62533mADC	0.2075VDC
-50mADC	-3.1221mADC	1.1875VDC
-100mADC	-6.2248mADC	2.375VDC



6.6.3.1. Operational Amplifier characteristics

The Operational Amplifier characteristics have strong impact on the test circuit.

As a guideline, the following requirements shall be applied to this component in order to ensure proper operation of the circuit and the sensor:

Item	Value
Voltage supply	Dual and high enough to the current range to be tested
Inputs	Rail to rail
Output	Rail to rail
Output current sink/source	$\geq \pm 25\text{mA}$
Output Slew Rate	$\geq 10\text{V}/\mu\text{s}$
GBW	$\geq 20\text{MHz}$
Input offset voltage	$< 1\text{mV}$
Other	Fast recovery of output from saturation Phase reversal free

6.6.3.1. DIODE and MOSFET characteristics

The diode shall have the following characteristics:

Item	Value
Type	Schottky (fast switching with no recovery losses)
Reverse Voltage	$\geq 20\text{V}$
Forward continuous current	$\geq 200\text{mA}$
Forward voltage	$\leq 300\text{mV @ } 10\text{mA}$

The MOSFET will operate in both switching and linear modes. It shall have the following characteristics:

Item	Value
Drain-Source Voltage	$\geq 20\text{V}$
Drain Current	$\geq 200\text{mA}$
Gate-Source Threshold Voltage	$1\text{V} \leq V_{GS} \leq 3\text{V}$
Drain-Source ON state resistance	$\leq 1\Omega$



7. SW Integration

B-sample prototypes sensors implement following state machine. Customer must take into account this behavior for his design.

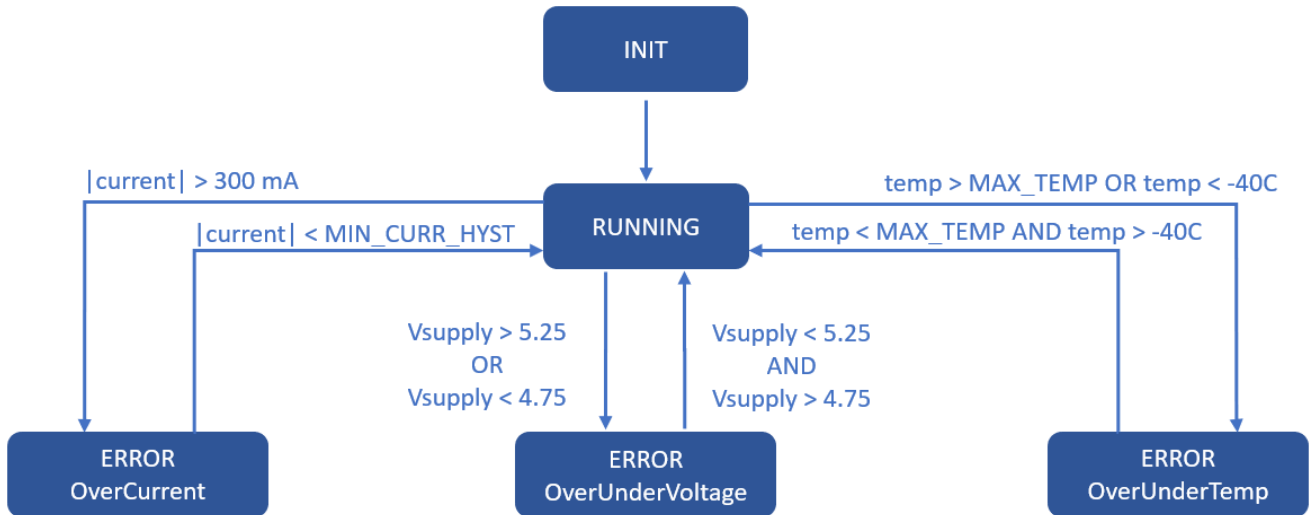

SPECIMEN

